

CASE STUDY:

Utilizing Lower-Cost “Smart” FFU Systems

*Providing a Flexible, Energy Efficient Cleanroom Environment
Utilizing Lower Cost Single-Phase AC FFU Systems*

JIM SCHWARTZ, CRAIG VERNICK, AND HOWARD ABRAMOWITZ

WHEN FACED WITH THE DESIRE to upscale cleanroom installations utilizing a fan filter unit design, most companies find the increased complexity and cost of a control system to be a prohibitive price to pay. A combination of smart design, innovation, and new product availability are giving companies the option of upgrading to “smarter” systems without having to pay the upscale price. Tiered solutions matching the desired “smarts” with budget constraints are available for low cost AC FFU platforms. This case study examines one installation that utilized these approaches to achieve a cost-effective blend of performance, flexibility, and efficiency without having to leap into a “high-end” solution.

Program Requirements

Cleanroom environment: A three room installation consisting of 308 FFUs. The main Cleanroom is a Class 10 with 255 FFUs. The other rooms are Lab Maintenance (21 FFUs) and Gowning Room (32 FFUs). Improved performance, reduced energy consumption along with maintenance and flexibility were considerations within an aggressive cost budget.

Design Considerations

For ease of maintenance it was decided to use FFUs that had room-side replaceable filters. To improve the running cost, an evaluation of the filter media was initiated. A decision to use a deep pleat design of 70 mm ULPA filters was made to reduce the air flow resistance and improve the efficiency of the FFU system. Finally a smart control system was considered to allow for ease of installation along with reduced energy costs and flexibility to adjust the cleanroom environment to the changing needs of the company. Balancing and recalibration of the rooms would be simplified with a smart system in place.

Smart building automated systems (BAS) were reviewed. Systems using energy efficient DC fan-motor driven FFUs were evaluated. The options explored for this installation exceeded \$50,000—typically adding \$200 to \$300 per FFU to the system solution. A lower cost approach was needed to meet the budget constraints.

One solution was to go back to AC fan driven systems but use a more efficient fan/blower system. A

high efficiency AC fan/blower assembly was installed in the FFU at a nominal cost that reduced the fan current drain (at 277 volt) from >1.0 ampere per fan to under 0.7 ampere per fan.

The FFU used in this system was a Clean Rooms International SAM24 FFU, with a room side replaceable; 70 mm depth filter media and an efficient 277v AC motor/blower. This provided an efficient AC platform for this application while addressing ease of maintenance.

In order to address the “smart” benefits generally limited to the DC brushless systems, Clean Rooms International offered the customer a smart Small Cleanroom Control System from AirCare Automation, ➤

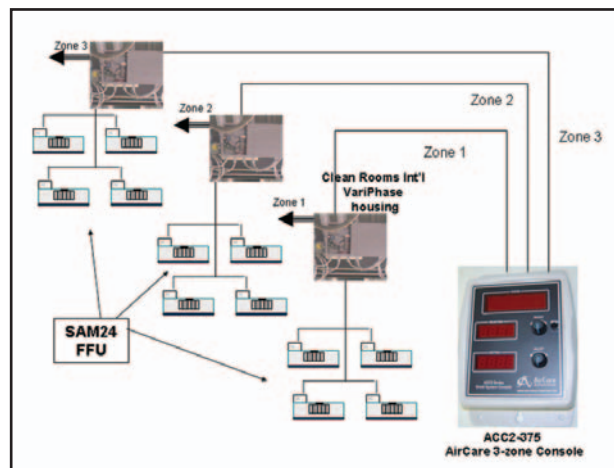
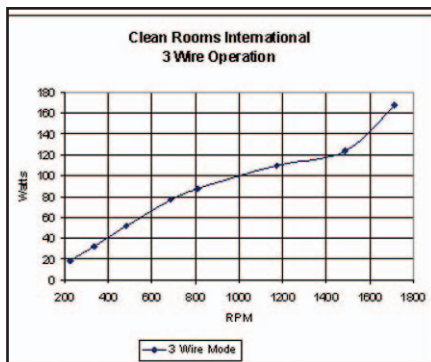

Figure 1: Clean Rooms International solution using AirCare Automation Small System solution



Energy Efficient FFU fan shows significant reduction in power usage at lower than full speed

Inc. The system uses an AirCare VariPhase™ Controller (“VariPhase”) to control the AC fans that are “networked” to a conveniently placed AirCare Console. The key features of the VariPhase that was of benefit to Clean Rooms International and the customer:

- ▶ **Unique Addresses:** Each VariPhase controlled independently from the Console. Fan speeds can be set/adjusted from outside the cleanroom without breaching the cleanroom. Intrusion into the cleanroom is eliminated and the adjustment is performed in moments.
- ▶ **FFU Grouping:** Each VariPhase can drive multiple fans. Grouping of up to 4 FFUs per VariPhase results in installation cost reduction and enhances balancing/adjusting capability as well as reducing the time required at start-up. Each individual grouping of FFUs can be uniquely set/adjusted to accommodate room layout and equipment placement modifications.
- ▶ **3-wire improved performance:** VariPhase controls reduce the current drain per FFU, reduces fan “hum” and reduces motor heating for extended life of the FFU.
- ▶ **Soft-Start:** AC fans have a start-up current draw of 2 – 2.5 times the run current. Using VariPhase adjustable soft start, start-up to under 0.8 Amperes.
- ▶ **Set Back:** The AirCare Console™ implements a one command FFU set-back to save energy during the

off (unoccupied) hours. This feature also extends filter life.

- ▶ The combination of the fan choice, 3-wire control and soft-start resulted in an installation platform placing 20 FFUs on each 20 Ampere breaker; a major cost savings in installation cost at the customer site.
- ▶ FFU grouping with AirCare VariPhase™ allowed Clean Rooms International to use 82 VariPhase units to control all the FFU systems (combining 2-4 FFU per VariPhase).
- ▶ The FFU groupings were separated into 3 zones (Class 10 cleanroom, Lab Maintenance Room and Gowning Room) controlled by a 3-zone AirCare Console (ACC2-375) for individual room control/set-back feature.

Installation Impact

In order to ease the installation of the 2-4 FFU groupings to each VariPhase interconnect, Clean Rooms International designed and built special “quick-connect” VariPhase controller housings for installation during electric system “rough-in”. This allowed the AC fans to be pre-wired to a quick-connect mate before ceiling installation and the VariPhase connection interface was pre-wired in the special housings to 4 quick-connect nodes before the cleanroom ceiling installation. The 4-node VariPhase boxes could then be easily installed to the AC breaker line and the FFUs independently mounted in the ceiling and then rapidly installed through the quick connect nodes.

As noted earlier, using low energy fans, variable controls (3-wire opera-

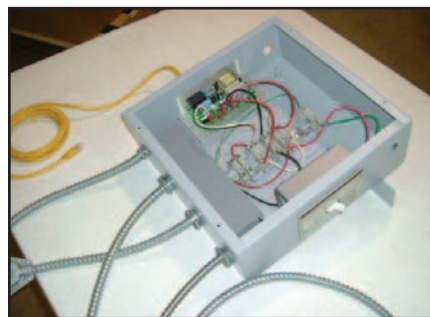

Clean Rooms Int'l VariPhase control housing.

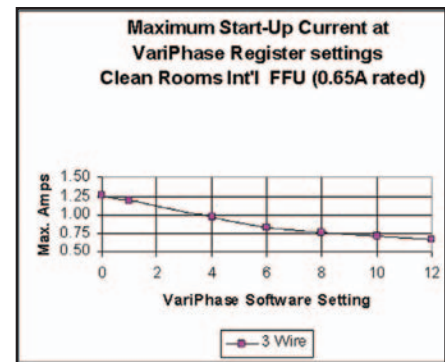

Start-Up Characteristics of each FFU using AirCare VariPhase™ Soft-Start Option

tion) and soft-start, enabled the installer to reduce the number of installed breaker lines (20 Ampere) by 11. The network communication was also easy to implement as each zone uses a daisy chain connection of pre-formed patch cables (CAT5 network cable with RJ45 connections) to connect the AirCare Console to the respective VariPhases in each zone.

Estimated \$11,000 Savings

At an installed cost of \$500 per breaker line the AirCare Small System cost is offset by >\$5,000 (11 breaker lines saved). Estimates of installation and balance time saved at least 15 minutes per FFU. At a \$80/hour installation/balance fee savings of >\$6,000 (\$20- ea. x 308 FFUs)

Resulting Benefits

System Cost: Smart system implementation cost of less than 25% of alternative “smart systems”.

Performance: Deep-pleated filters reduce pressure drop which saves energy. Filter module baffling and VariPhase 3-wire operation reduces audible noise. Optimized balancing enabled by the Console/VariPhase system along with their imbedded set-back feature saves energy all year long.

Energy Efficiency: Compared to the original AC system, the customer will save almost 60% of the electric power. Lower run-current fan, improved bal-

FILTER TYPE	AVERAGE WATTS	TOTAL	KWHR SAVED/YR
Standard FFU	315	2750	0
Efficient (AC) FFU	170	1500	1250
Balanced FFU (88% RPM)	120	1100	1600
Set-Back (25% (2 day + 8 hrs/day -5 days))	100	925	1850

Table 1. Kilowatt-hours saved per year

FFU TYPE	Amp/FFU	Start Amps/FFU	FFU/20 A Breaker	# of Breaker AC Lines
Std. FFU	1.1 amps	>2.0 amps	8-10	32-40
CI FFU w/ss	0.65 amps	0.8 amps	20-25	15-20

Table 2. Reduction of breaker lines

ancing resulting in not overrunning the cleanroom combined with 3-wire energy-saving operation are the primary contributors. An additional 20-25% of the remaining energy can be saved by "off-time" set-back utilization (total reduction of almost 70%).

Savings Estimate: Average savings per FFU of 200 watts operating results in >1700 kW hrs per year, at \$0.12 per kW hr. That results in >\$200 savings per FFU each year. (See Table 1)

Installation: Quick-connect Vari-Phase housing and quick-connect

...a smart control system was considered...to adjust the cleanroom environment to the changing needs of the company.

mate FFUs made installation seamless. The reduction on breaker lines reduced material and electrical contractor cost. Balancing the three rooms from an easy-to-use wall mounted console reduces balancing time (and cost) by more than 50%. (See Table 2)

Maintenance: Room side replaceable filters, quick connect FFU and VariPhase housings along with modular AirCare Console makes maintenance/repairs/modifications easy. Isolated shut-down through smart systems control provide sectional

Constant use of your standard disinfectant may be causing residue build up on your floors, stainless steel and softwalls—but, you don't want to use a neutral cleaner that may add contamination.

Micronova's range of detergents includes several free-rinsing solutions, all filtered to 0.1 microns with extremely low ion counts. You can trust our products to maintain the integrity of your Cleanroom or Production Area every day.



Clean³



Your Cleanroom's Worth It!™

www.micronova-mfg.com
888-81 MICRO

3431 West Lomita Boulevard
Torrance, CA 90505-5010

NovaClean

Detergent concentrate. Filtered to 0.1 microns. For general cleaning in cleanrooms.

NovaHol

Ready to use cleaner with alcohol. Filtered to 0.1 microns. Decreases bioburden.

MegaClean

Removes heavy soils and adhesive residues.



▲ Circle No. 13 on Free Product Info. Card

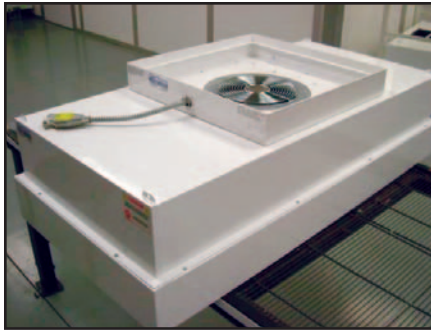

Clean Rooms International SAM24 fan filter unit.

isolation to enable upgrade/maintenance operations to take place without facility disruption. Reduced (optimized) air-flow and deeper filter depth results in extended filter life.

Conclusion

The resulting system provides options to cleanroom customers previously caught between expensive "smart systems" using DC fans and touting top efficiency and full automation, and

Compared to the original AC system, the customer will save almost 60% of the electric power.

"no control" inefficient AC systems which limited individual fan control, but which require breaching the cleanroom to make adjustments. The options presented here allow solutions that match the pocketbook limits with a range of "smartness" to provide the best combination and tradeoff of "smarts vs. cost" to meet the users needs.

Innovative FFU design and implementation of low cost AC "smarts" provide many of the key benefits of the automation systems at a fraction of the cost, resulting in investment paybacks of one year or less for most applications. Innovative design, product choice and "grouping" consider-

ations can provide a customer a matrix of cost-performance tradeoffs that will let the customer stay within budget, yet receive improved performance, reduced installation cost and lower ongoing maintenance costs.

Jim Schwartz, Sales Engineer is with Clean Rooms International, 3718 Buchanan Avenue SW, Grand Rapids, MI 49548. He can be reached at 616-452-8700 or jims@cleanroomsint.com.

Craig Vernick is President of Vernick & Associates, Inc. 445 W. Liberty Street Suite 226, Medina, Ohio 44256. He can be reached at 330-723-7010 or cvernick@apk.net

Howard Abramowitz, Ph.D. EE, is President of AirCare Automation, Inc., 9532 Oakmore Road, Los Angeles, CA 90035. He can be reached at 310-836-3715 or howard@aircareautomation.com.

Does your copy of *Controlled Environments Magazine*™ mysteriously disappear from your desk each month?

(Although we like pass-along readership, you may prefer to keep your copy just for yourself.)

Help your co-workers get their own subscriptions: look for the "refer a colleague" button on the *Controlled Environments* web site (www.cemag.us) and complete the easy-to-use form.

We'll send them an e-mail telling them how they can qualify to receive *Controlled Environments Magazine* every month.



www.cemag.us

REFER A COLLEAGUE TODAY!

Considering Cleanroom Garment Rental, Lease or Purchase?

Consider...



1st Prudential Cleanroom Services™
A Division of Prudential Overall Supply

Since 1960, Prudential Cleanroom Services has remained First in Cleanroom Laundry Processing Services for critically controlled environments.

1st in Building Relationships	1st in Accountability
1st in Commitment	1st in Experience
1st in Availability	1st in Capacity & Capabilities
1st in Sterility Assurance	

800-767-5536

www.pcs-clean.com

Mesa AZ • Los Angeles CA • Milpitas CA
Denver CO • Austin TX • Richmond VA • Tijuana MX

ISO 9001:2000 Certified
Prudential Cleanroom Services has established and applies a Quality Management System for Providing Woven and Non-Woven Cleanroom Apparel and Contamination Control Products for Controlled Environments



▲ Circle No. 15 on Free Product Info. Card